

**NEW** 

# CAIS E-BOX "M" 6.0 + 8.0

CANTILEVER HARDWARE

# E-BOX "M"

## E-BOX "M" 6.0

### SET

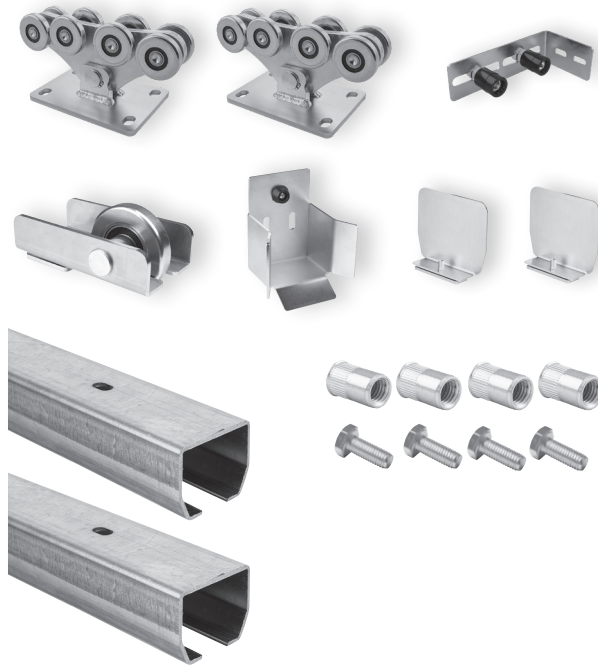

SPEED ME .....2 pcs  
 STAGE MZ 2,85.....3 pcs  
 RUN M .....1 pc  
 LAST M .....1 pc  
 PILOT MN .....2 pcs  
 FRM 2 .....1 pc  
 PARK CSM .....1 pc  
 BOLT M10x25 .....24 pcs  
 RIVET NUT .....24 pcs

ART. SET / kg

E-BOX "M" 6.0.....127,1kg

GATES UP TO

LENGHT ..... 6 m

CODE: 1710077

## E-BOX "M" 8.0

### SET

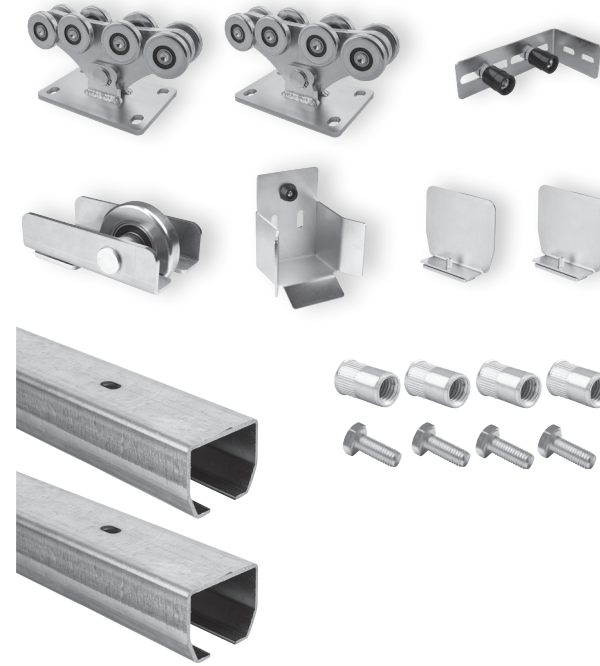

SPEED ME .....2 pcs  
 STAGE MZ 2,85.....4 pcs  
 RUN M .....1 pc  
 LAST M .....1 pc  
 PILOT MN .....2 pcs  
 FRM 2 .....1 pc  
 PARK CSM .....1 pc  
 BOLT M10x25 .....32 pcs  
 RIVET NUT .....32 pcs

ART. SET / kg

E-BOX "M" 8.0.....158,4kg

GATES UP TO

LENGHT ..... 8 m

CODE: 1710078

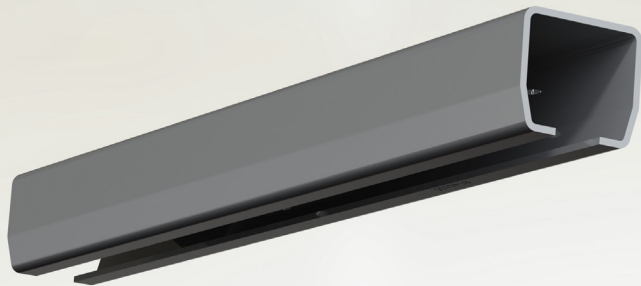

**W Wuppermann**  
GERMAN STEEL

GALVANIZED  
INTERNAL  
EDGES



**270**  
g/m<sup>2</sup>

HOT  
DIPPED  
GALVANIZED

SPECIAL  
THICKNESS

**5,00**  
mm



- 37°C  
TESTED  
& PROVEN



+ 50°C  
TESTED  
& PROVEN



**24**  
months

24 MONTHS  
TESTED  
& PROVEN



MADE IN  
CZECH  
REPUBLIC

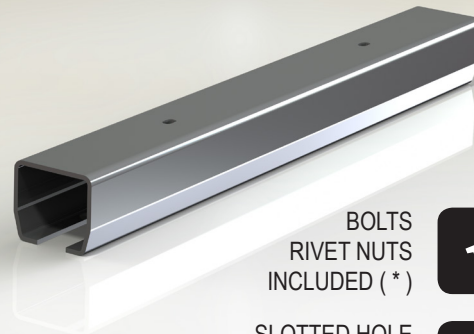

BOLTS  
RIVET NUTS  
INCLUDED ( \* )



SLOTTED HOLE  
PUNCHED EVERY  
400mm IN TRACK



SERIAL NUMBER  
CARRIAGE  
TESTED & PROVEN



EASY  
ASSEMBLY



FAST  
NO WELDING  
REQUIRED

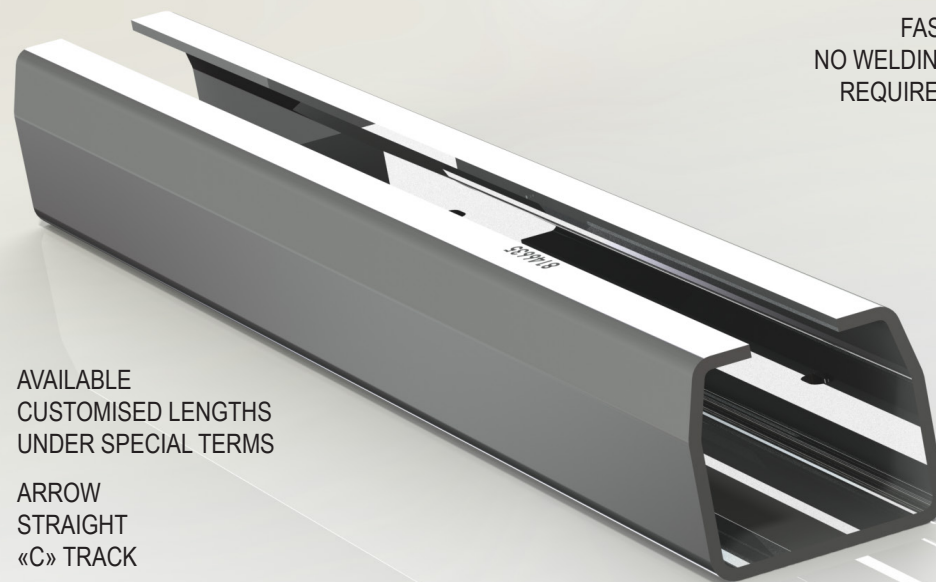

AVAILABLE  
CUSTOMISED LENGTHS  
UNDER SPECIAL TERMS



ARROW  
STRAIGHT  
«C» TRACK



EIGHTEEN ROLL FORMERS  
THE LARGEST NUMBER IN THE INDUSTRY  
REMOVE THE INSET «MEMORY» OF THE STEEL











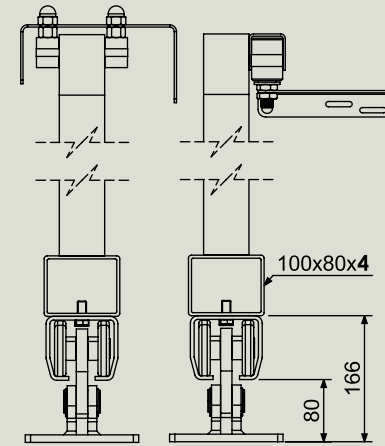









SLOW ROLLING  
NO HEAT GENERATED DURING PRODUCTION  
KEEPING THE MATERIAL WHERE IT IS ROLLED



BRNO  
UNIVERSITY  
OF TECHNOLOGY

CANTILEVER M									
	mm; kg	mm; kg	mm; kg	mm; kg	mm; kg	mm; kg	mm; kg	mm; kg	mm; kg
A	4000	4500	5000	5500	6000	6500	7000	7500	8000
max. weight gate	500 kg	525 kg	550 kg	575 kg	600 kg	625 kg	650 kg	675 kg	700 kg
B	1200	1350	1500	1650	1800	1950	2100	2250	2400
C	1860	2010	2160	2310	2460	2610	2760	2910	3060
D	330	330	330	330	330	330	330	330	330



-  EASY ASSEMBLY
-  FAST NO WELDING REQUIRED
-  BOLTS RIVET NUTS INCLUDED (\*)
-  «C» TRACK SERIAL NO. 100% COMPATIBILITY CARRIAGE TESTED
-  GERMAN STEEL
-  270 g/m<sup>2</sup> HOT DIPPED GALVANIZED
-  ARROW STRAIGHT «C» TRACK
-  SLOTTED HOLE PUNCHED EVERY 400mm IN TRACK
-  GALVANIZED INTERNAL EDGES
-  MADE IN CZECH REPUBLIC
-  C 2 HIGH QUALITY BEARINGS
-  CARRIAGES CENTER HOLES MILLED NOT LASER CUT
-  MULTI RIVETED SECTIONS
-  JAPANESE ROBOTICS FANUC
-  UNIVERSITY OF TECHNOLOGY – BRNO
-  - 37°C TESTED & PROVEN
-  + 50°C TESTED & PROVEN
-  NO WELDING REQUIRED

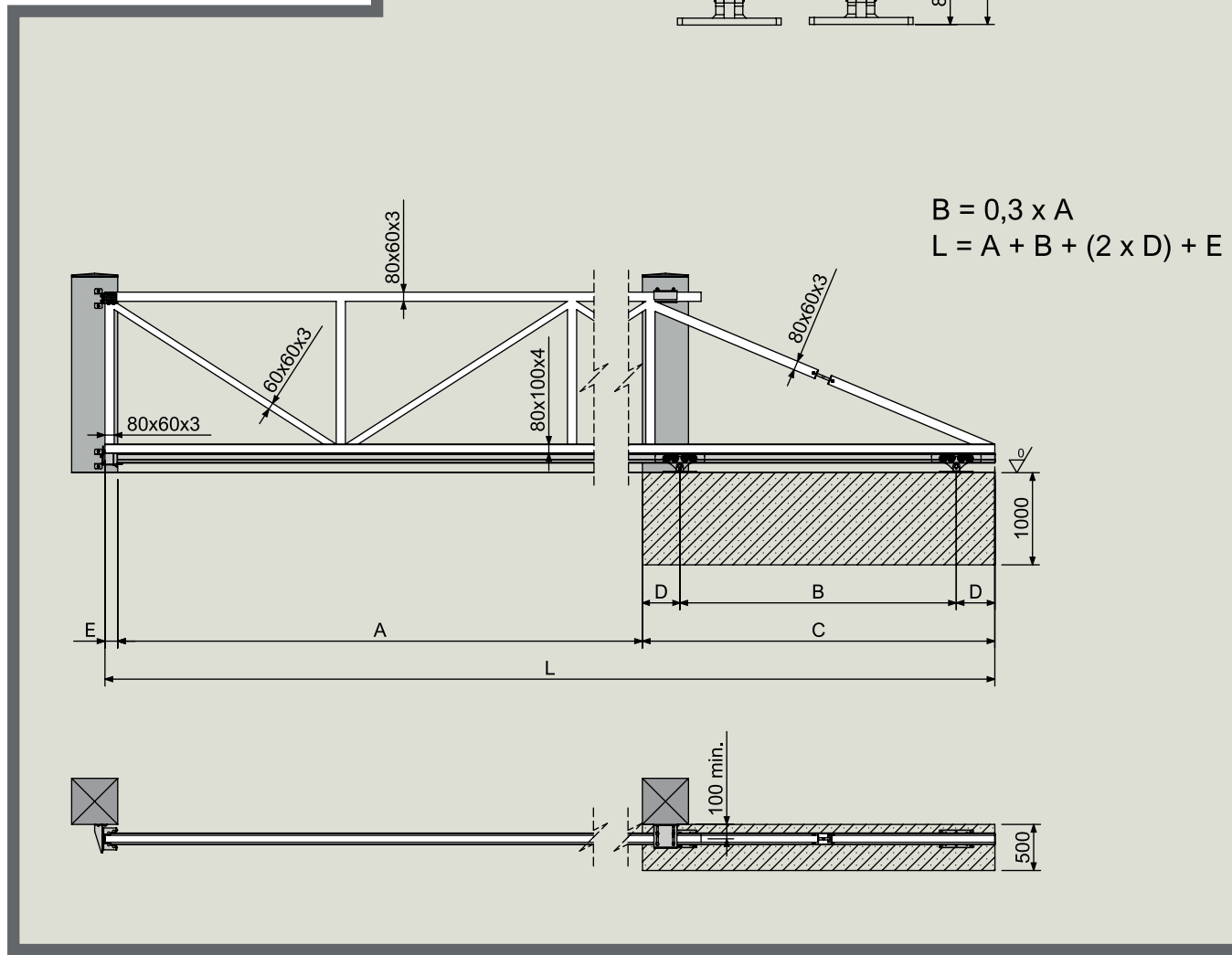

# CAIS MANUAL

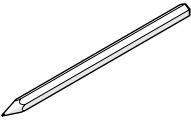
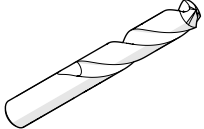
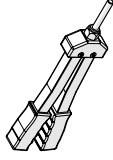
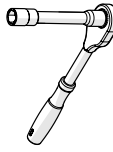
			
Pencil	Drill bit 13mm	Riveting pliers	Ratchet 17 mm

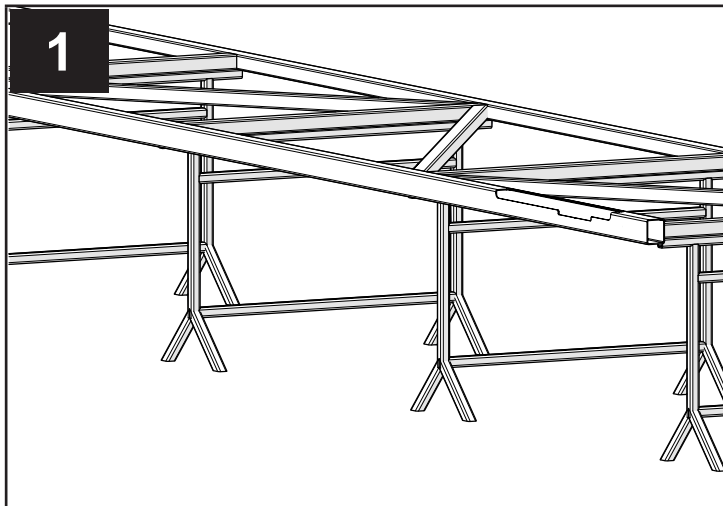
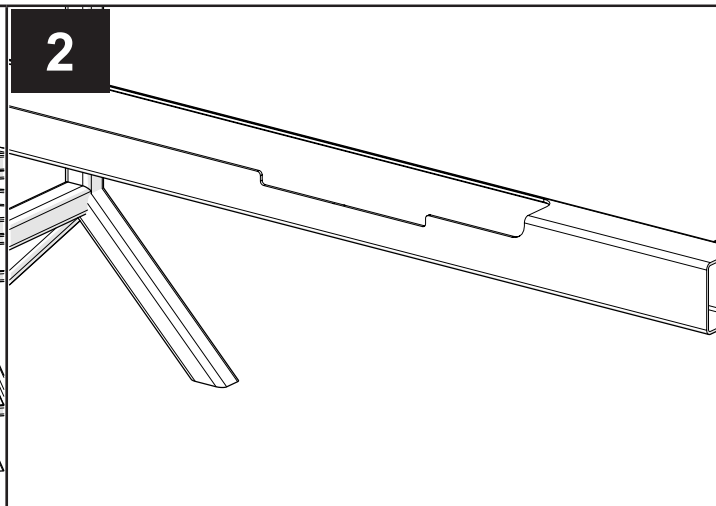
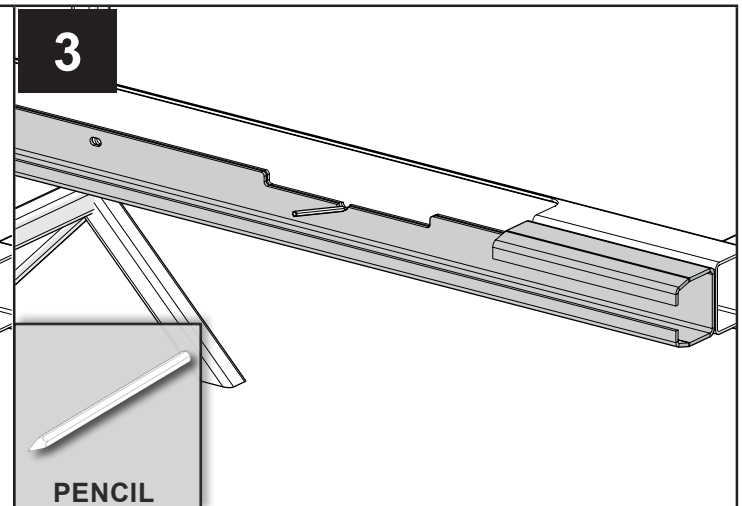
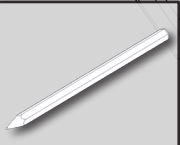
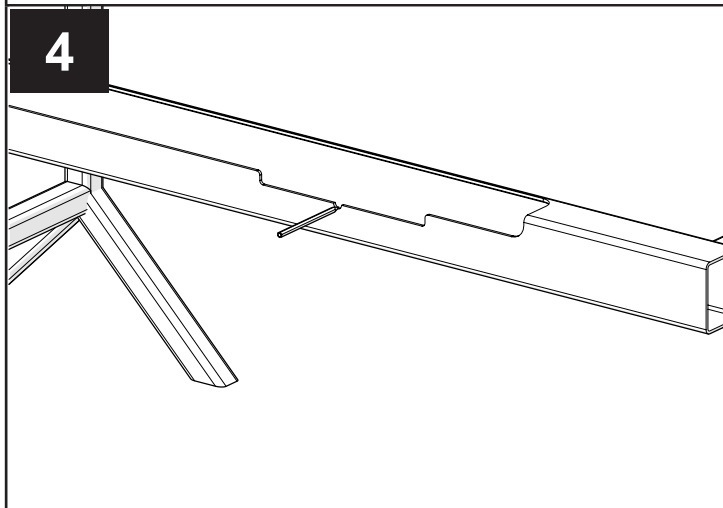
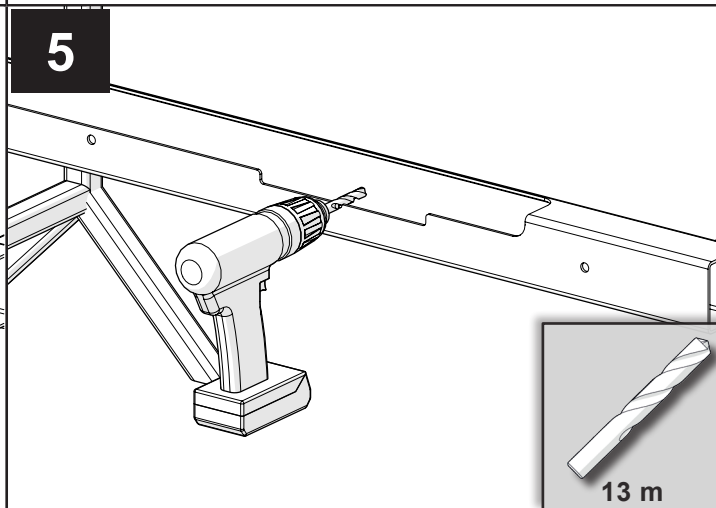
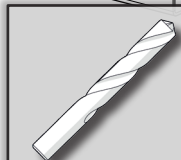
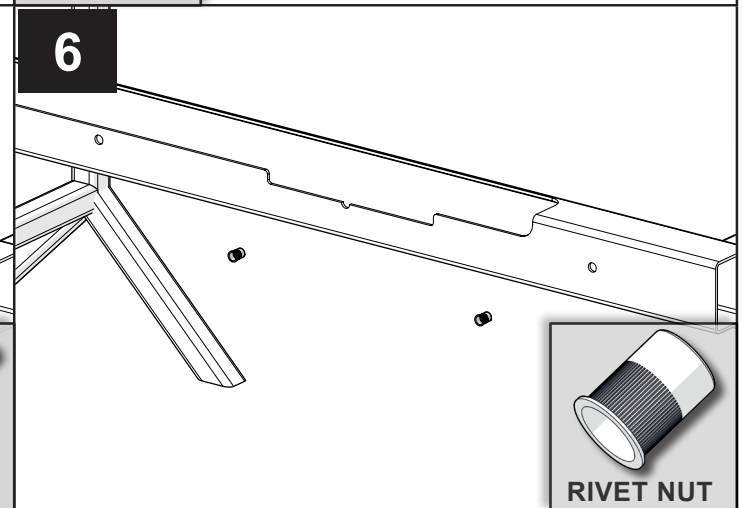
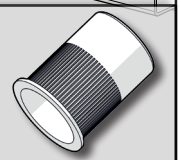
<b>1</b> 	<b>2</b> 	<b>3</b>   PENCIL
<b>4</b> 	<b>5</b>   13 m	<b>6</b>   RIVET NUT

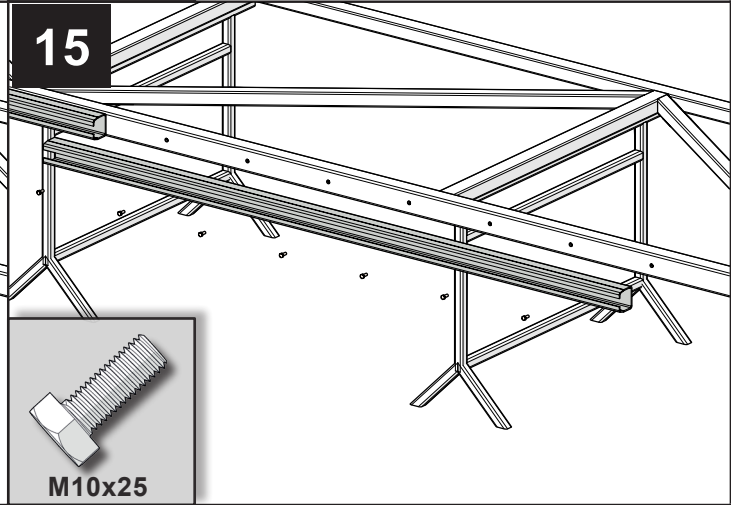
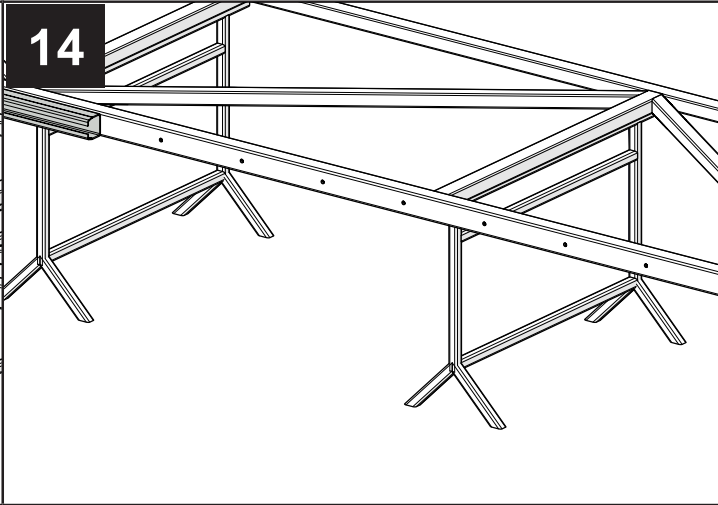
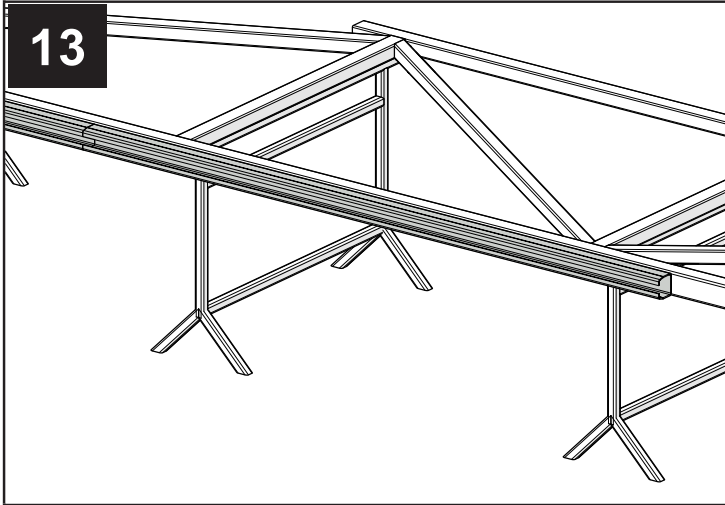
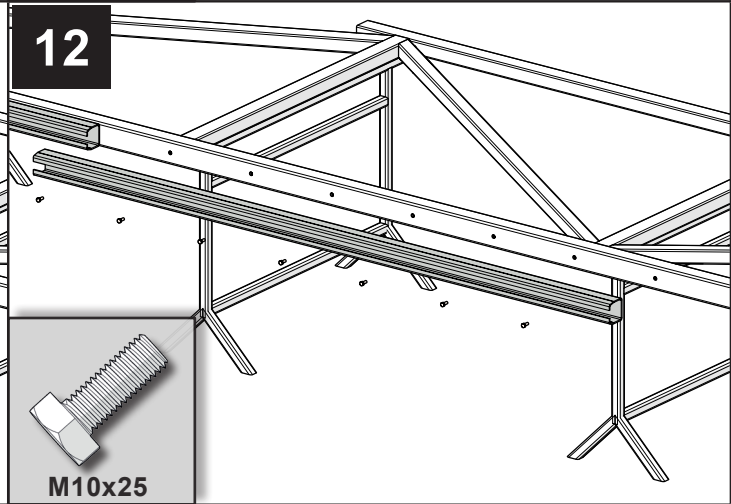
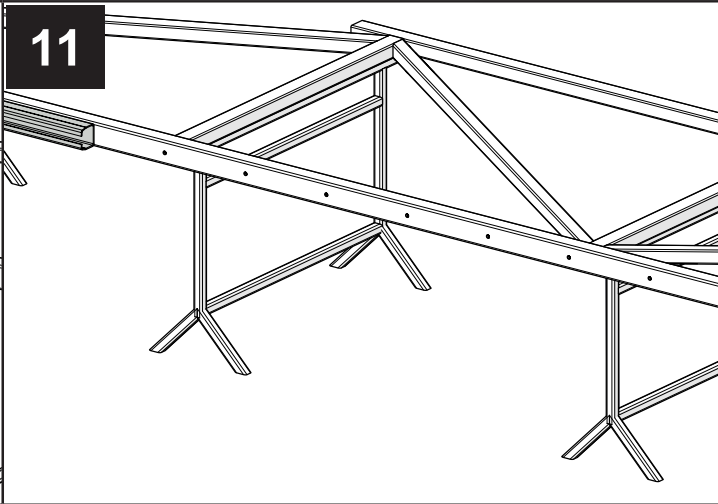
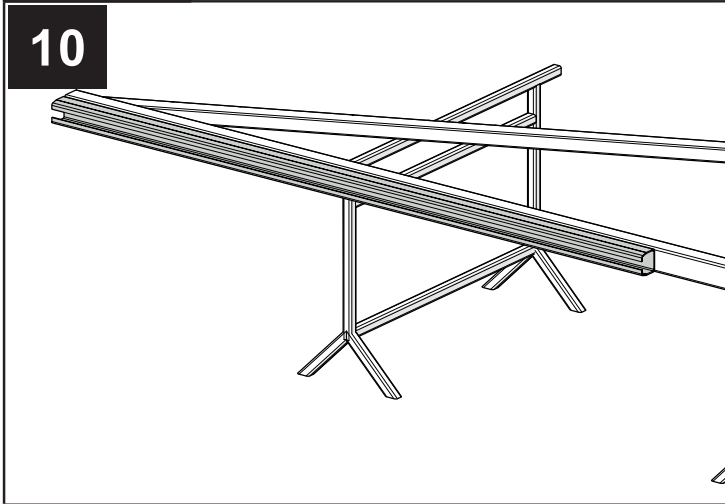
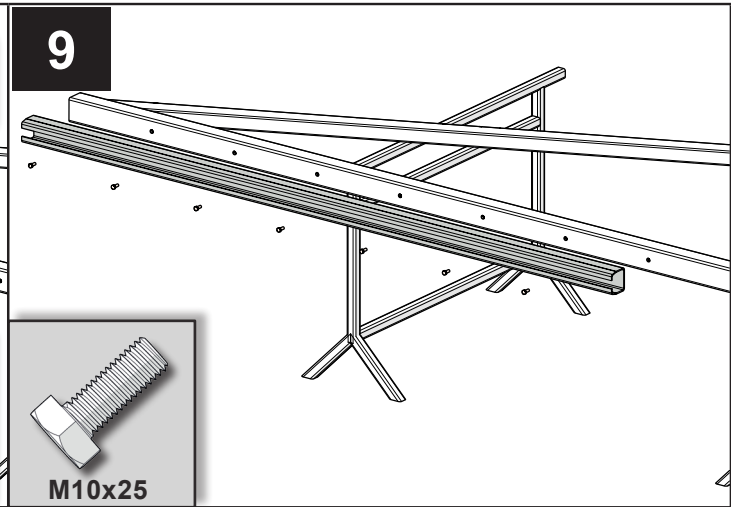
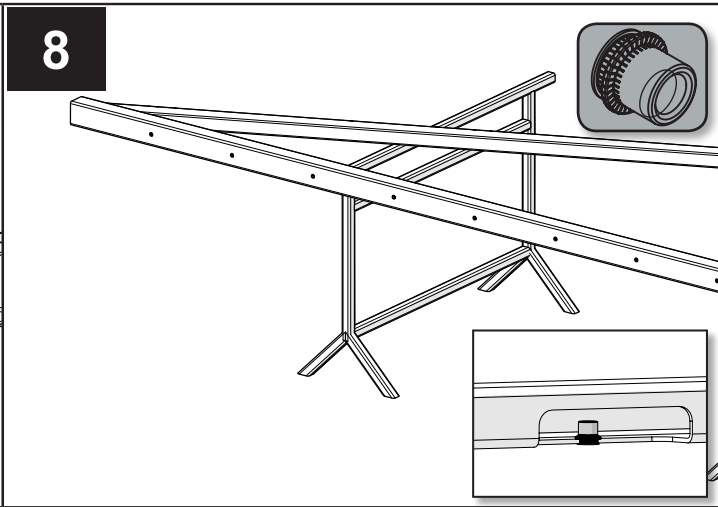
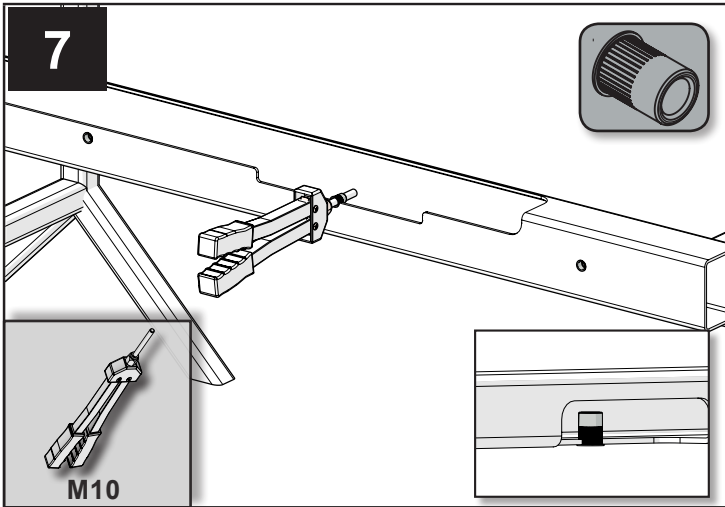

16

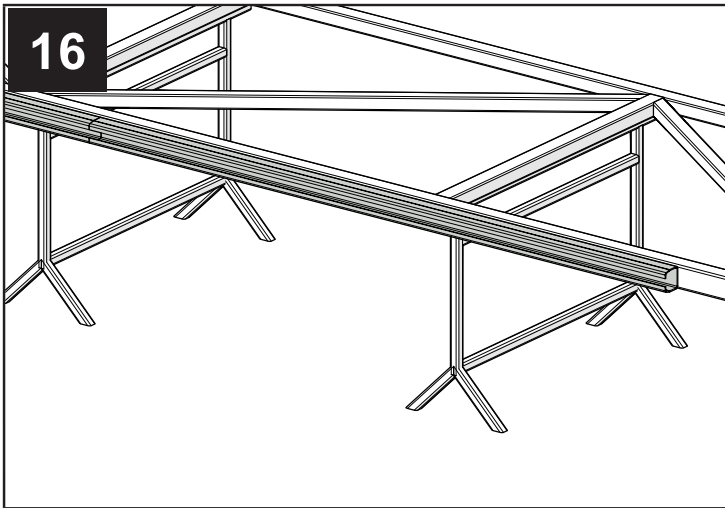

17

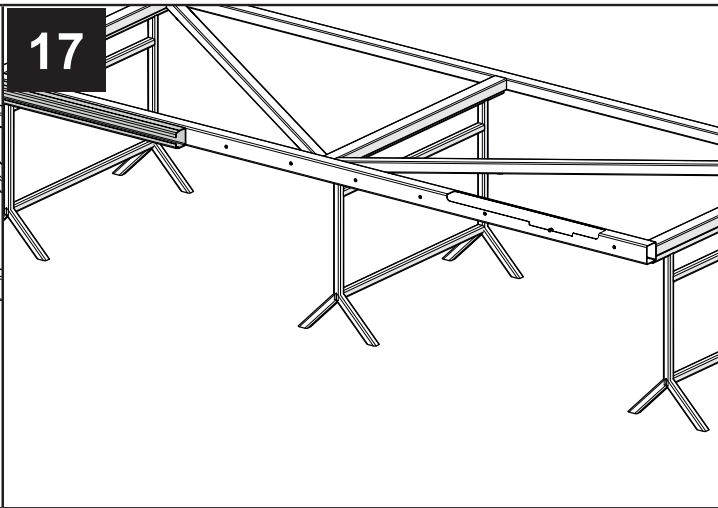

18

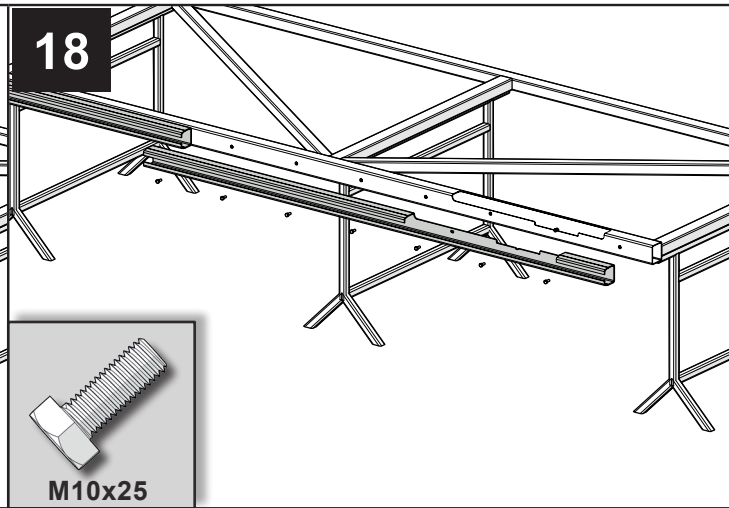

M10x25

19

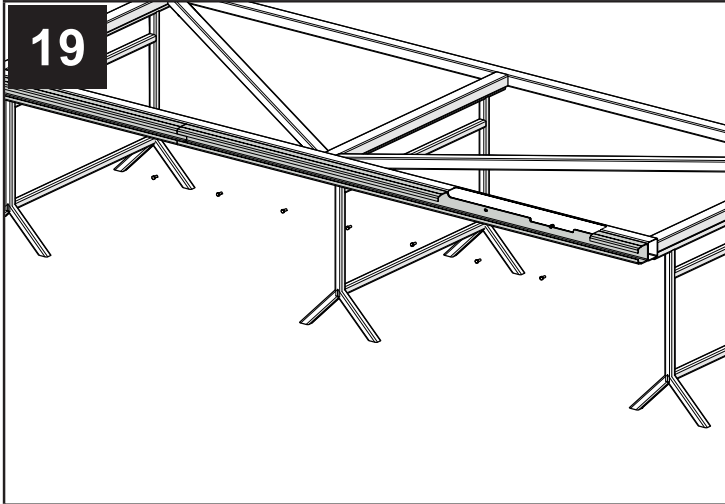

20

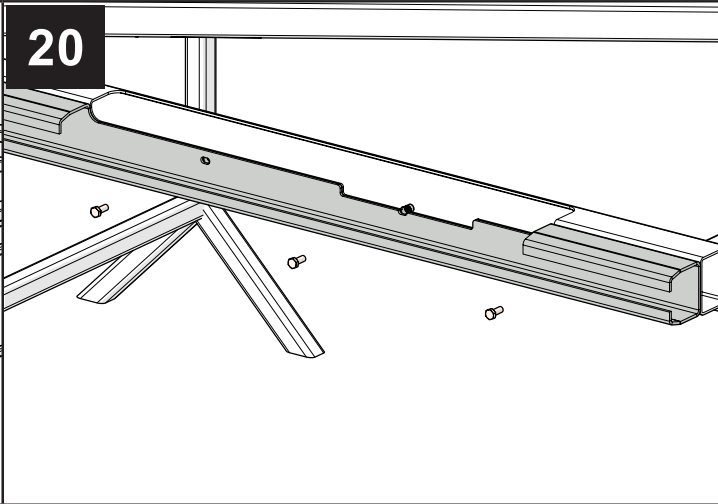

21

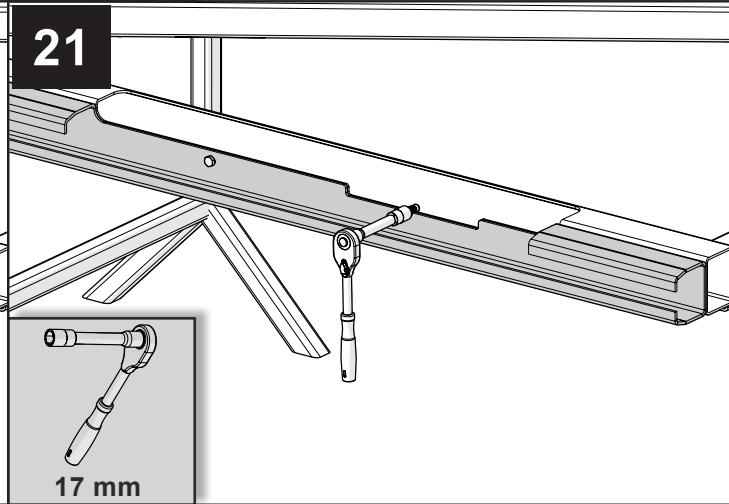

17 mm

22

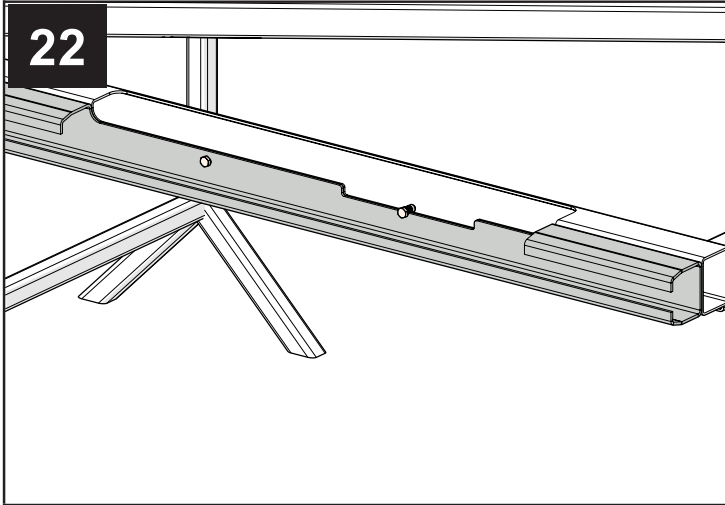

23

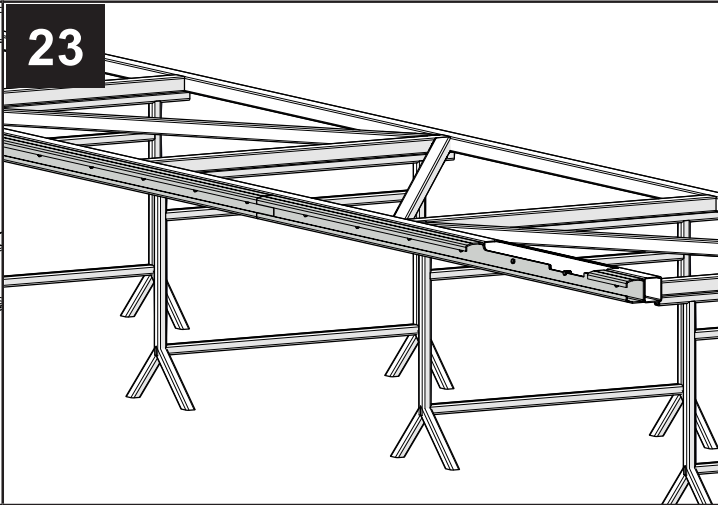

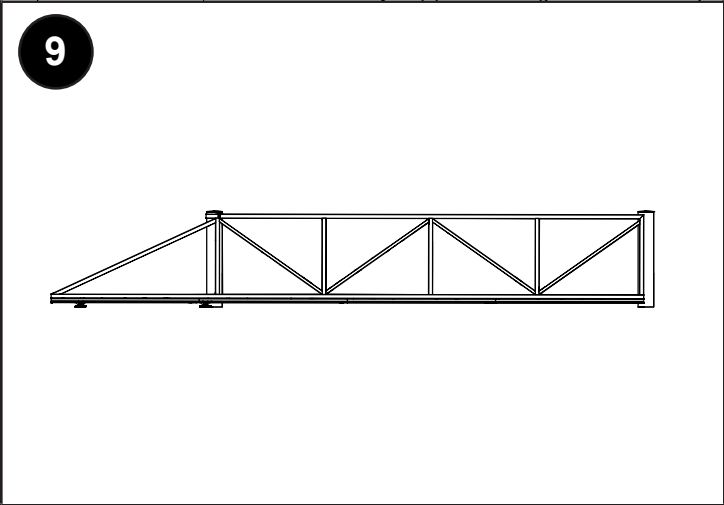
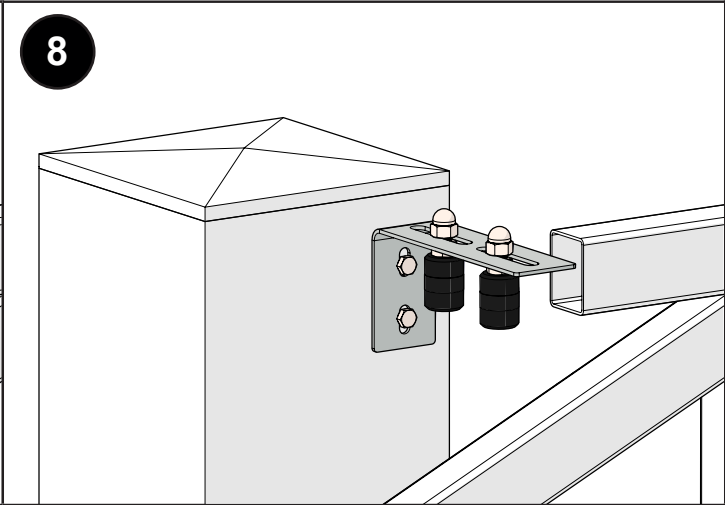
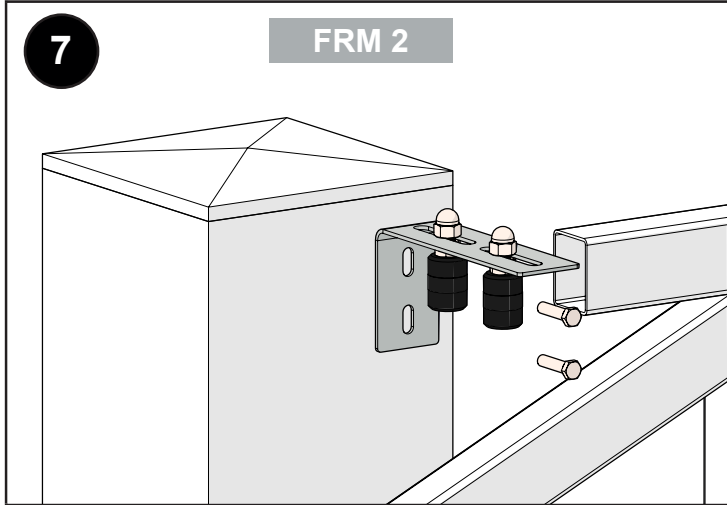
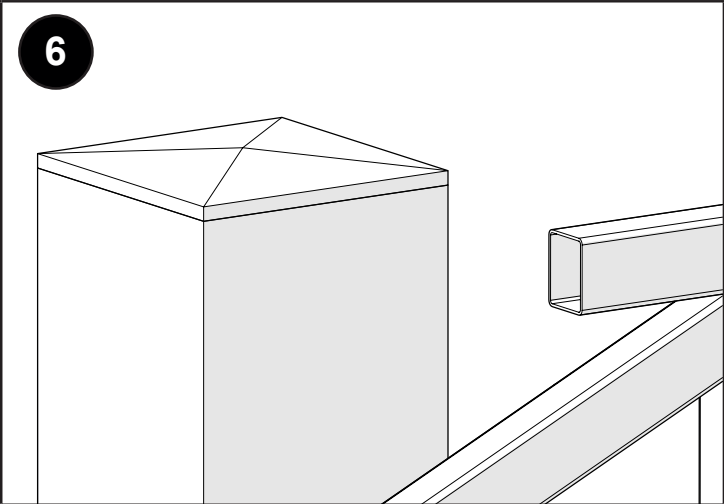
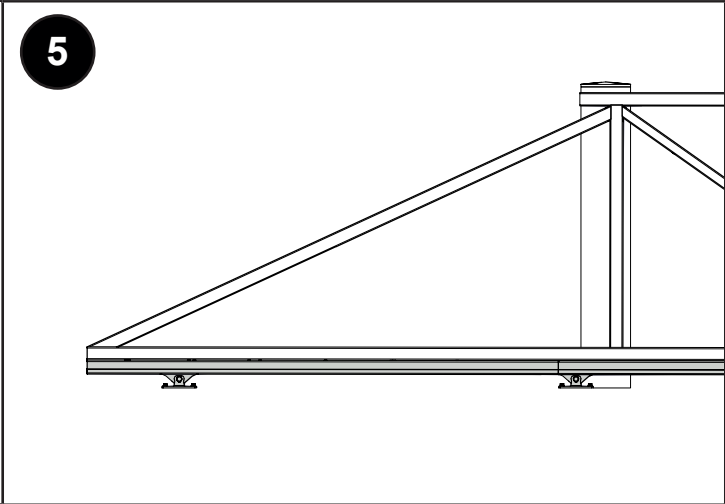
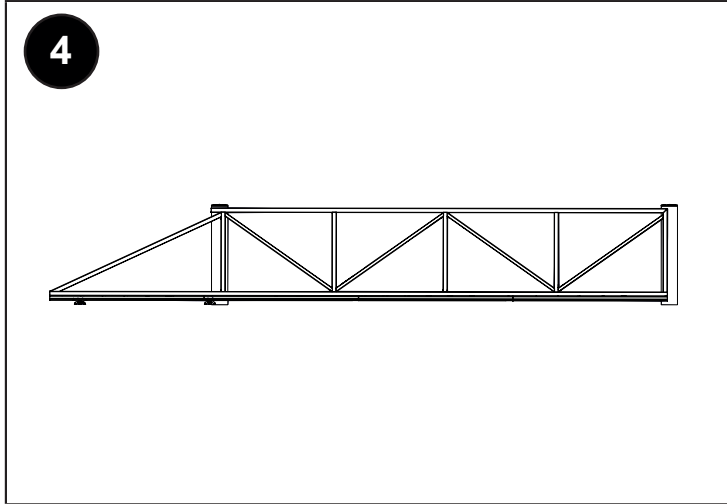
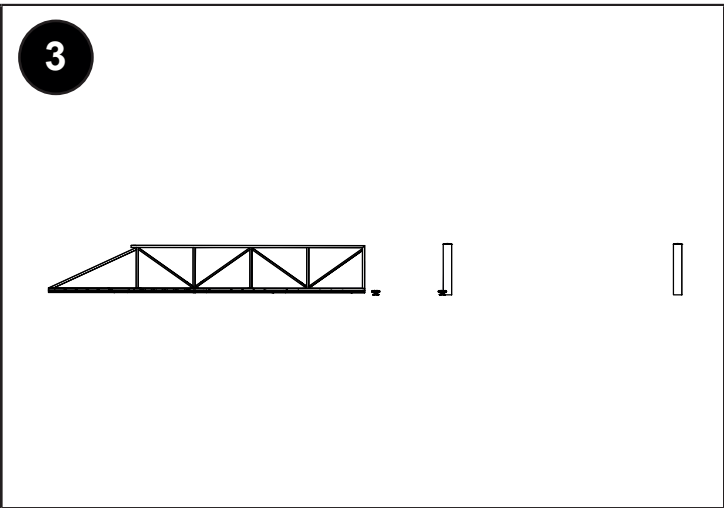
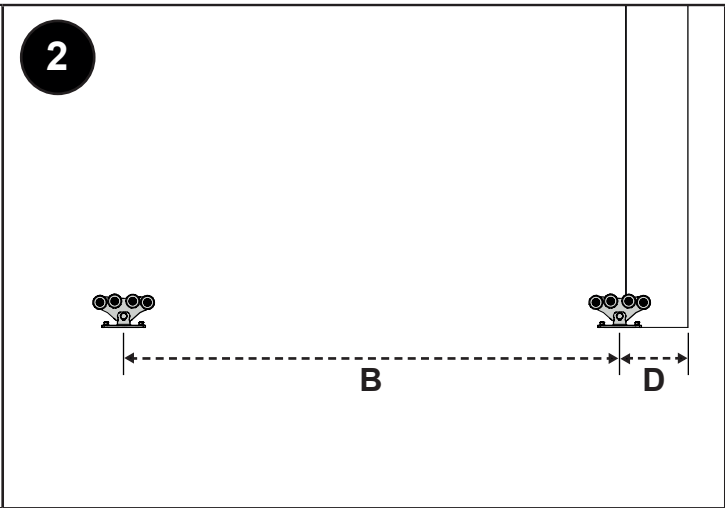
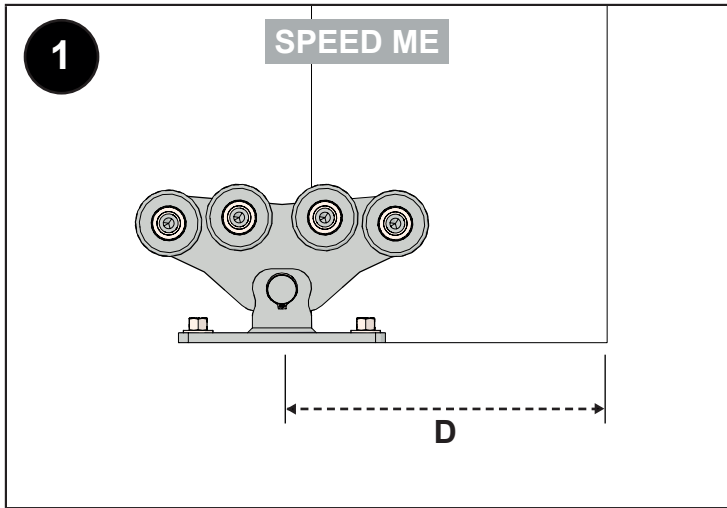



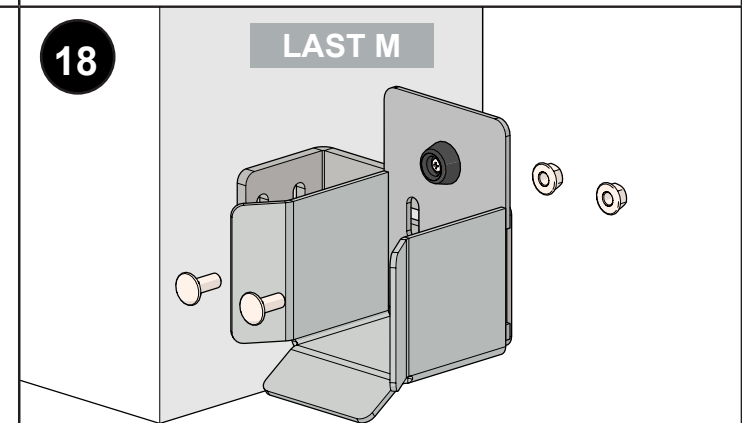
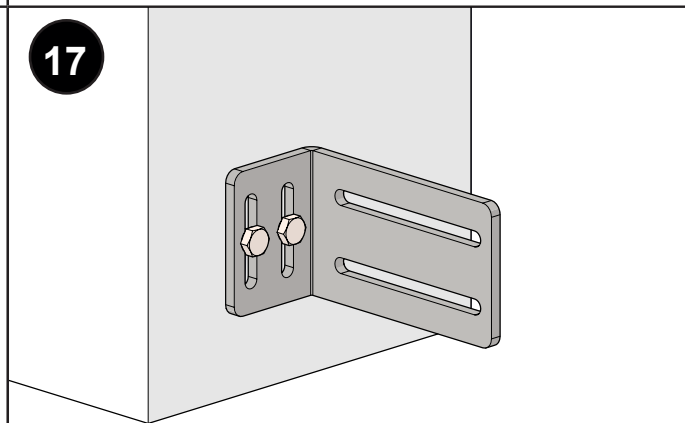
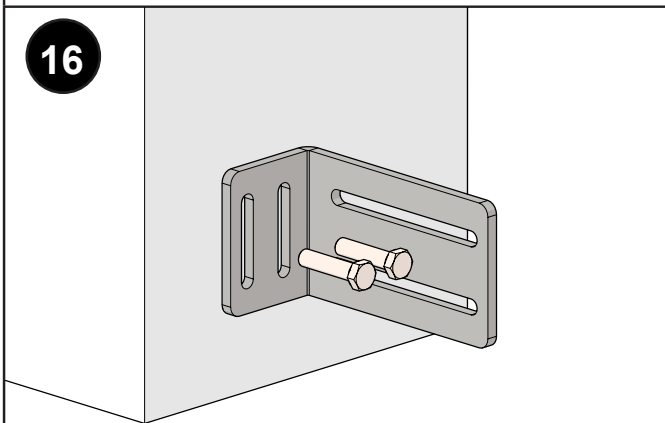
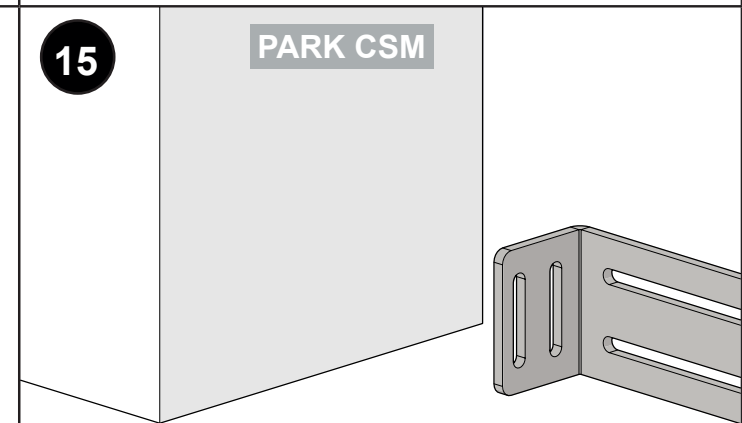
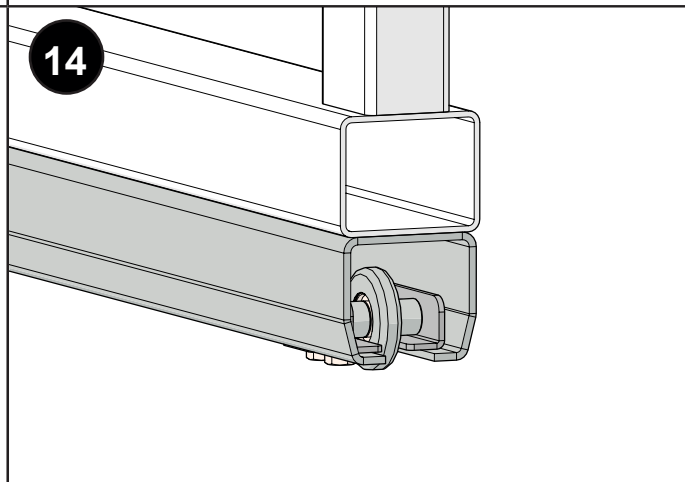
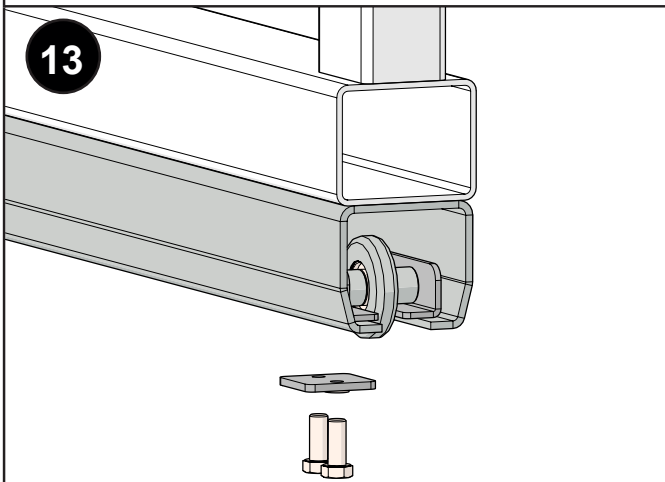
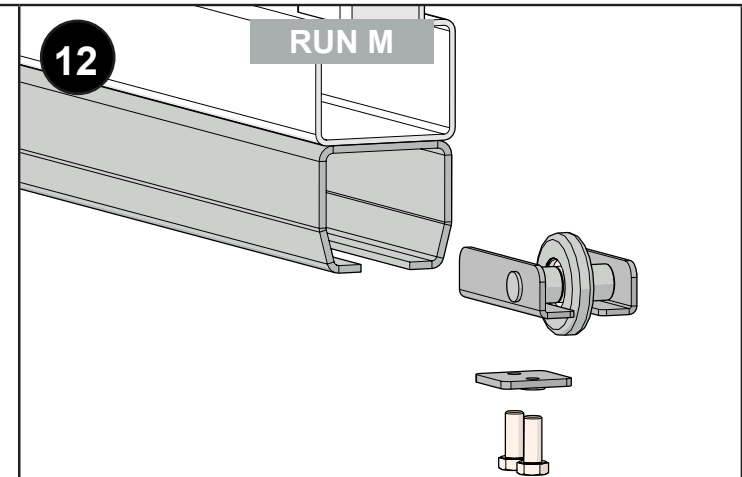
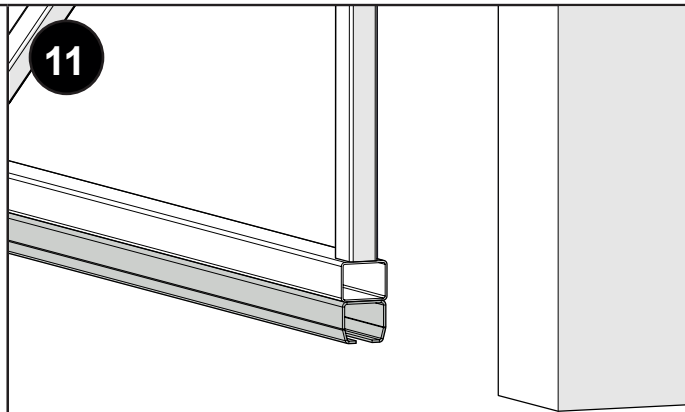
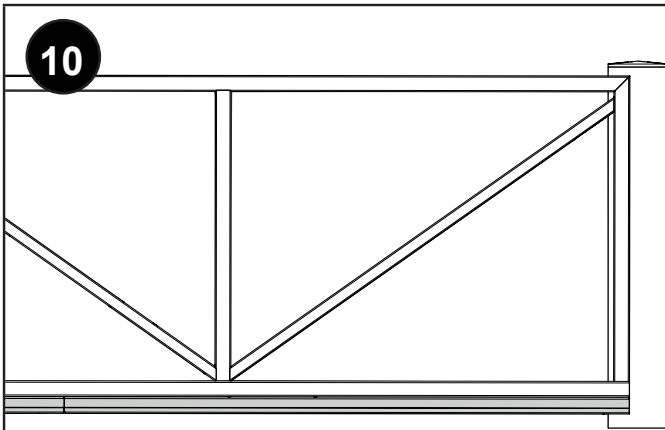

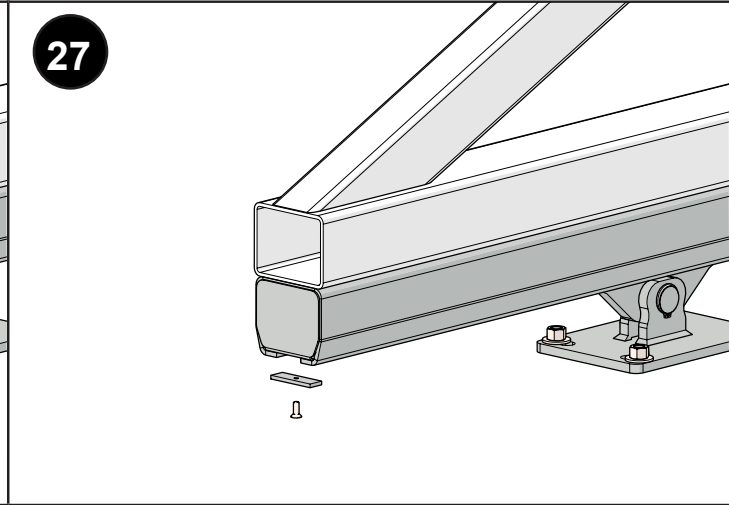
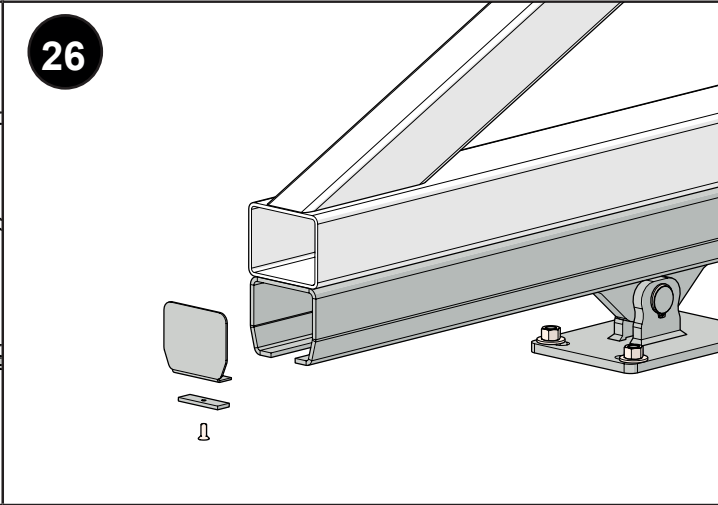
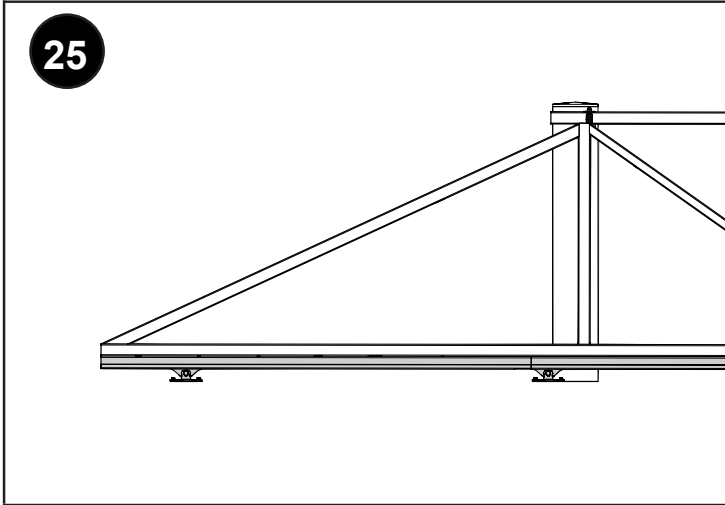
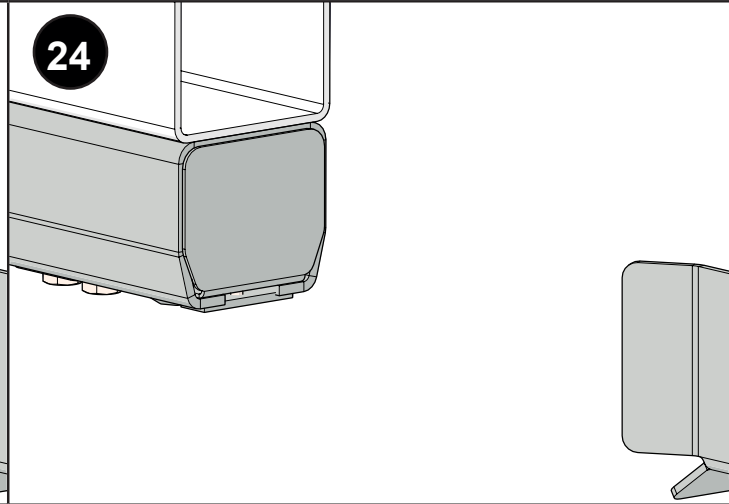
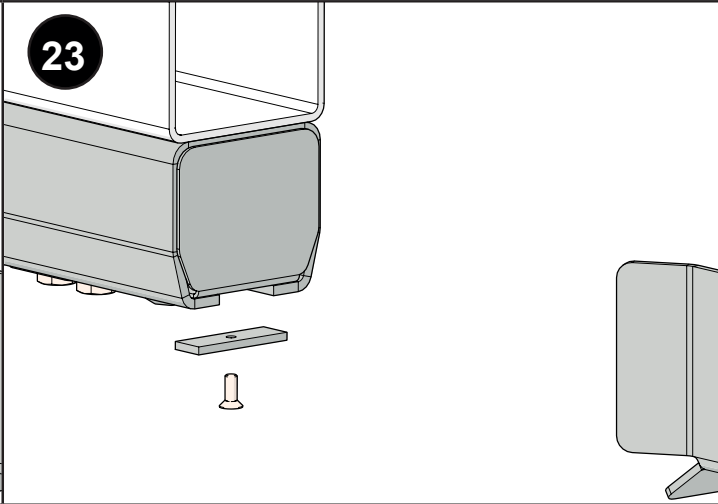
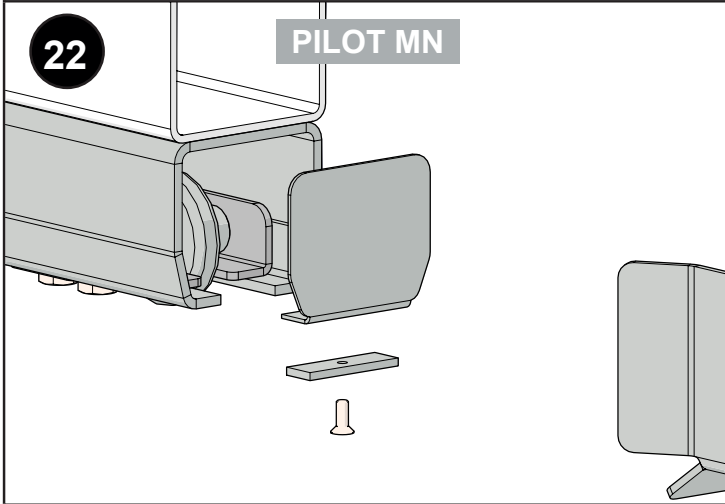
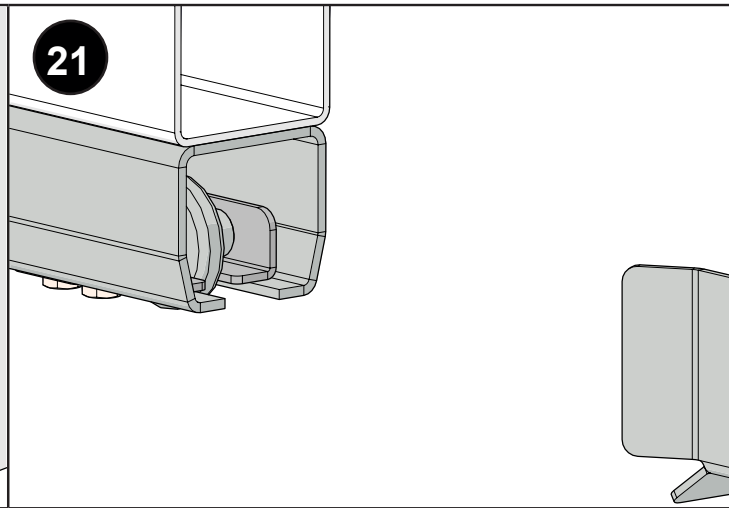
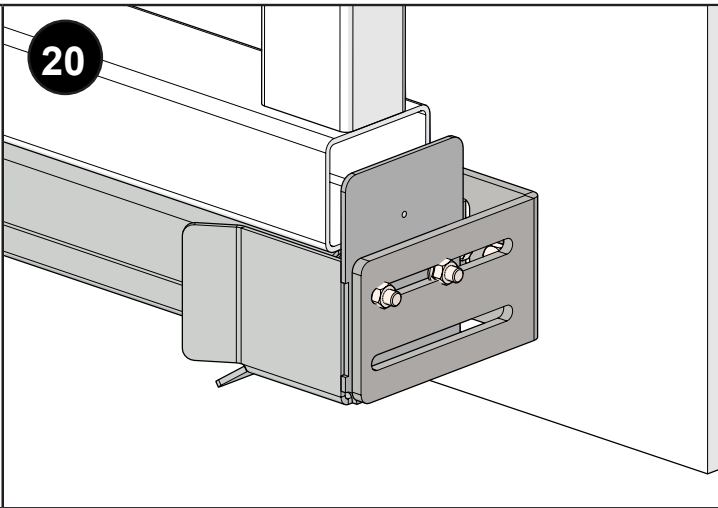
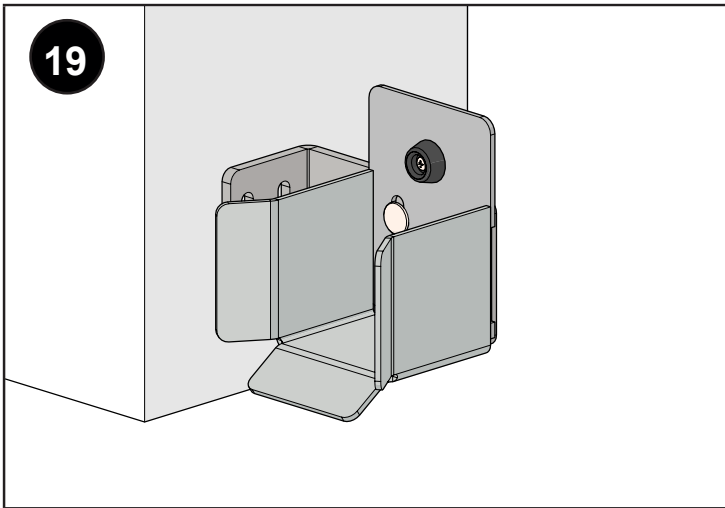

28

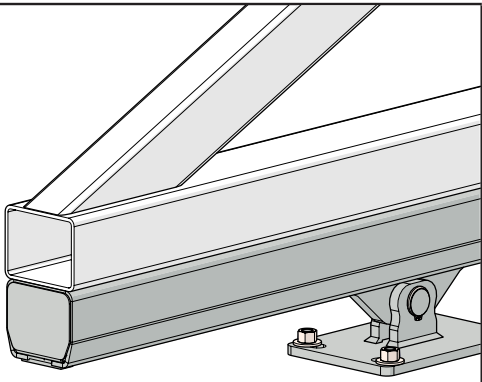

29

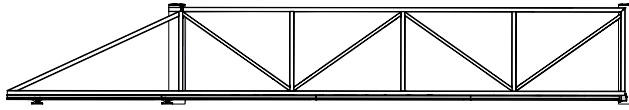

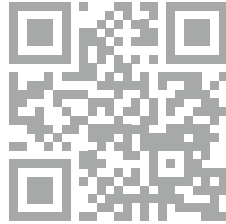

[www.cais.eu](http://www.cais.eu)